

STANDARD EQUIPMENT Includes:

- CO₂/N₂ Inflation System w/ Twin Oversized Buoyancy Tubes
- Three (3) Position (Closed, Sail & Convertible) Light Weight Canopy w/ Cinch Strap
- Sure-Seal™ Closures w/ #10 YKK Heavy Duty Zippering
- Dual Main Zipper w/ Ventilation Tie Backs
- Tripod Arch, Auto Inflatable, Canopy Support System w/ Stay Erect Arch Support Valve System
- Oversized Front Boarding Entry w/ 4 Rung Boarding Ladder
- Interior Assist Ladder w/ Quick-Release Fittings
- Rear Boarding Door w/ 3 Rung Boarding Ladder
- Five (5) Bowed Boarding Assist Handles
- Front boarding Assist Stirrups
- Combination Foul Weather Observation Port Hole & Water Collection System w/ Sure-Seal™ Closures
- I2DF™ Inflatable Insulated Double Floor
- Water Activated Interior/Exterior Survivor Locator Lights
- Quick-Grab™ Pelican® Super MityLite™ Flashlight on Arch
- Auto-Deploying Hemispherical Drogue (Sea-Anchor) w/ 25' Line & Dual Anti-Foul Swivels
- 75' Floating Heaving Trailing Line w/ Buoyant Throwing Handle
- 35' Painter Line w/ Quick-Release Fittings
- Heavy Duty EZGrip™ Righting Line w/ Contrasting Bowed Hand Grips
- Unidirectional Retro/Radar Reflective Segment across Arch
- Unidirectional Retro Reflective Segments under Life Raft & on Canopy
- Pentagonal Ballast System™
- 2" Exterior Lifelines & Interior Grasp Lines
- Five (5) StoreSafe™ Light Weight Dry Survival Gear Storage Pockets
- Pressure Relief Valves
- Topping-Up Valves
- Urethane Valise

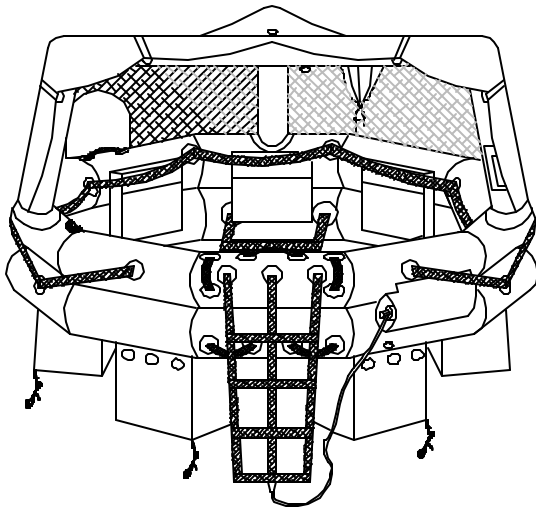

NOT TO SCALE

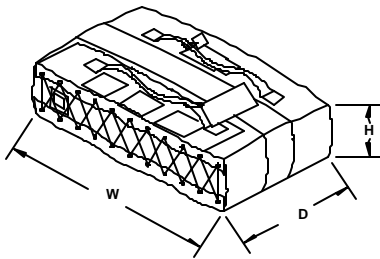

Part 91 & 121 SEP Kit Includes:

- ① Manual Inflation Pump – Spring Loaded Return w/ Adapter
- ① Raft Knife
- ① Repair Kit (Includes: Repair Tape, Repair Clamp (3") & 2 PRV Plugs w/ Tether)
- ① Collapsible Bailer Bucket w/ Handle
- ② Sponges
- ① Signal Mirror
- ① Rescue Streamer™ High Visibility Ribbon (6" X 25')
- ① USCG/SOLAS Whistle
- ① Oral Inflation Tube
- ① Extended Life Flashlight (sealed case)
- ② Spare Alkaline Batteries & Spare Super MityLite™ Xenon Bulb Assembly
- ③ USCG Aerial Meteor Flares
- ① USCG Hand Held Locator Flare
- Food Ration Bars (250 Cal./Person)
- Anti-Seasickness Tablets (6/Person)
- ① Utility Knife (SS Lockback)
- ① Retaining Line (75')
- ① Survival Manual
- ① Bible
- ① PUR Survivor "06" Watermaker

Part 135 SEP Kit Includes 91/121 Plus:

- ① Fishing Kit
- Food Ration Bars (1750 Cal./Person)
- ① Sea-Dye Marker
- ① Water Storage Bag
- ① Magnetic Compass
- ② Paddles w/ Retro Reflective Segments
- ① First Aid Kit: [First Aid/Burn Cream Packets (12), Antiseptic Towelettes (10), 1" X 3" Adhesive Strips (16), Nitrile Gloves (1 pair), Sterile Triangular Bandage, 4" Bandage Compress, First Aid Guide]

JAR-OPS1 SEP Kit Includes 91/121 Plus:

- ⑤ Additional USCG Aerial Meteor Flares
- ① Additional USCG Hand Held Locator Flare
- ① Water Storage Bag
- 6 Mil Poly Bags (1/Person)
- Food Ration Bars (2000 Cal./Total)
- ① First Aid Kit [Sun block (30SPF), Magnifier, Thermal Blanket, 4" Bandage Compress (4), Sterile Triangular Bandage (2), 2" Bandage Compress (12), Nitrile Gloves (1 pair), Antiseptic Towelettes (10), First Aid/Burn Cream Packets (12), 1" X 3" Adhesive Strips (16), Adhesive Tape, First Aid Guide]

JAR-OPS1/135 SEP Kit Includes 91/121 & JAR-OPS1 Plus:

- ① Fishing Kit
- Food Ration Bars (1750 Cal./Person)
- ① Sea-Dye Marker
- ① Magnetic Compass
- ② Paddles w/ Retro Reflective Segments

CAR SEP Kit Includes 91/121 Plus:

- ① Fishing Kit
- ① First Aid Kit (Same as FAR Part 135)
- ① Sea-Dye Marker
- ① Magnetic Compass
- ② Paddles w/ Retro Reflective Segments

ELT Options:

- Dual Frequency Survival (S) Type ELT, (121.5/243.0Mhz) 1.4 lbs. FAA TSO C91a
- Triple Frequency Survival (S) Type ELT, (121.5/243.0/406Mhz) w/ full Speech Capability on 121.5/243Mhz - 1.3 lbs. FAA TSO-C91a and C126

Please Note: ELT Requirements May Vary

Custom Dimensional Packing Available

Super-Light™ Ultima™ Valise Pack

Winslow Model	SEP Requirements	Dimension H X D X W	Total Weight	WINSLOW Part Number
46FASL Capacity 4 Ovid. Capacity 6	FAR PART 91 & 121	8" X 17" X 28"	42 lb.	46FASL-*190-1-100
	FAR PART 135	8" X 17" X 28"	47 lb.	46FASL-*130-1-100
	JAR-OPS1	8" X 17" X 28"	47 lb.	46FASL-*1J0-1-100
	JAR-OPS1/135	8" X 17" X 28"	60 lb.	46FASL-*1K0-1-100
57FASL Capacity 5 Ovid. Capacity 7	FAR PART 91 & 121	8" X 17" X 29"	43 lb.	57FASL-*190-1-100
	FAR PART 135	8" X 17" X 29"	48 lb.	57FASL-*130-1-100
	JAR-OPS1	8" X 17" X 29"	48 lb.	57FASL-*1J0-1-100
	JAR-OPS1/135	8" X 17" X 29"	61 lb.	57FASL-*1K0-1-100
69FASL Capacity 6 Ovid. Capacity 9	FAR PART 91 & 121	9" X 17" X 32"	53 lb.	69FASL-*190-1-100
	FAR PART 135	9" X 17" X 32"	59 lb.	69FASL-*130-1-100
	JAR-OPS1	9" X 17" X 32"	56 lb.	69FASL-*1J0-1-100
	JAR-OPS1/135	9" X 17" X 32"	71 lb.	69FASL-*1K0-1-100
710FASL Capacity 7 Ovid. Capacity 10	FAR PART 91 & 121	9" X 18" X 32"	54 lb.	710FASL-*190-1-100
	FAR PART 135	9" X 18" X 32"	60 lb.	710FASL-*130-1-100
	JAR-OPS1	9" X 18" X 32"	57 lb.	710FASL-*1J0-1-100
	JAR-OPS1/135	9" X 18" X 32"	72 lb.	710FASL-*1K0-1-100
812FASL Capacity 8 Ovid. Capacity 12	FAR PART 91 & 121	9" X 17" X 33"	59 lb.	812FASL-*190-1-100
	FAR PART 135	9" X 17" X 33"	66 lb.	812FASL-*130-1-100
	JAR-OPS1	9" X 17" X 33"	62 lb.	812FASL-*1J0-1-100
	JAR-OPS1/135	9" X 17" X 33"	79 lb.	812FASL-*1K0-1-100
913FASL Capacity 9 Ovid. Capacity 13	FAR PART 91 & 121	9" X 17" X 34"	60 lb.	913FASL-*190-1-100
	FAR PART 135	9" X 17" X 34"	67 lb.	913FASL-*130-1-100
	JAR-OPS1	9" X 17" X 34"	63 lb.	913FASL-*1J0-1-100
	JAR-OPS1/135	9" X 17" X 34"	80 lb.	913FASL-*1K0-1-100
1015FASL Capacity 10 Ovid. Capacity 15	FAR PART 91 & 121	9" X 18" X 34"	66 lb.	1015FASL-*190-1-100
	FAR PART 135	9" X 18" X 34"	75 lb.	1015FASL-*130-1-100
	JAR-OPS1	9" X 18" X 34"	70 lb.	1015FASL-*1J0-1-100
	JAR-OPS1/135	9" X 18" X 34"	88 lb.	1015FASL-*1K0-1-100
1116FASL Capacity 11 Ovid. Capacity 16	FAR PART 91 & 121	9" X 18" X 35"	67 lb.	1116FASL-*190-1-100
	FAR PART 135	9" X 18" X 35"	76 lb.	1116FASL-*130-1-100
	JAR-OPS1	9" X 18" X 35"	71 lb.	1116FASL-*1J0-1-100
	JAR-OPS1/135	9" X 18" X 35"	89 lb.	1116FASL-*1K0-1-100
1218FASL Capacity 12 Ovid. Capacity 18	FAR PART 91 & 121	9" X 18" X 36"	70 lb.	1218FASL-*190-1-100
	FAR PART 135	9" X 18" X 36"	81 lb.	1218FASL-*130-1-100
	JAR-OPS1	9" X 18" X 36"	75 lb.	1218FASL-*1J0-1-100
	JAR-OPS1/135	9" X 18" X 36"	95 lb.	1218FASL-*1K0-1-100
1320FASL Capacity 13 Ovid. Capacity 20	FAR PART 91 & 121	9" X 19" X 36"	71 lb.	1320FASL-*190-1-100
	FAR PART 135	9" X 19" X 36"	82 lb.	1320FASL-*130-1-100
	JAR-OPS1	9" X 19" X 36"	76 lb.	1320FASL-*1J0-1-100
	JAR-OPS1/135	9" X 19" X 36"	96 lb.	1320FASL-*1K0-1-100

WEIGHTS & RATES DO NOT INCLUDE Dual Frequency Survival (S) TYPE ELT

*SEP Kit configuration defines type of ELT and applicable regulation as shown below.

Example 1: -230 (Dual Frequency w/ FAR Part 135 compliant SEP Kit)

Example 2: -3K0 (Triple Frequency w/ JAR-OPS1 and FAR Part 135 compliant SEP Kit)

•1=No ELT •2=Dual Frequency •3=Triple Frequency •4=Triple Frequency/GPS¹ •5=Triple Frequency/GPS¹ w/ voice
¹Upon Availability

CAR Survival Equipment Packages are also available for WINSLOW Models 46FASL through 1320FASL by special request.